



Counter Top Coolers

SG1CTH COMPACT COUNTER TOP COOLER

- Stimulates Impulse Sales
- Compact Space Design
- On Premise Merchandising
- Stainless Steel Cabinet
- Low Energy Double Pane Tempered Glass Door
- Illuminated Sign Header
- Illuminated Interior
- 2 Non-adjustable Removable Shelves
- Eco Friendly R134A Refrigerant
- Adjustable Levelers
- UL Listed
- Custom Door Lock



**IN-HOUSE CUSTOM
GRAPHICS CAPABILITIES**

SG1CTH

Specifications

Product Facings (estimated)

Per Shelf:

- Four(4) of 2" Diameter Containers
- Three (3) of 2.5" Diameter Containers
- Two (2) of 3" Diameter Containers

Dimensions

- Packing: 15"W x 17.25"D x 26.5"H
- Exterior: 13"W x 15"D x 23.5"H
- Net Wt: 53 Pounds
- Gross Wt: 60 Pounds

Truck Load

- 24 Per 40 x 48 Pallet
- 40'-480 Units
- 53'-624 Units

Counter Top Cooler

- Stimulates Impulse Sales
- Compact Space Design
- On Premise Merchandising
- Static Refrigeration
- Stainless Steel Cabinet
- Low Energy Double Pane Tempered Glass Door
- Recessed Handle
- Custom Door Lock
- Factory Engineered Refrigeration System
- Eco Friendly R134A Refrigerant
- 1/10 Hp Compressor 1.24 Amp/115V
- 10' Power Cord
- UL Listed
- Illuminated Sign Header
- Illuminated Interior
- 2 Non-adjustable Removable Shelves
- Coated Heavy Wire Construction Shelves
- Adjustable Levelers

Dimensions 13"W x 15"D x 23.5"H

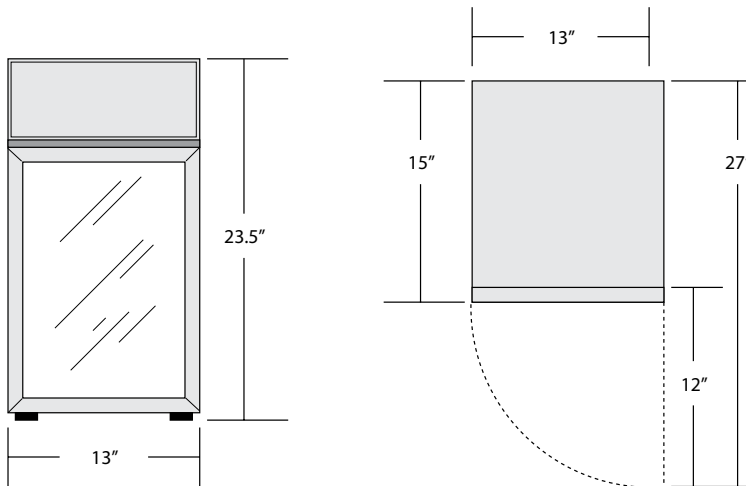

Interior Dimensions

8.75"W x 9.75"D x 12"H

Estimated Bottles / Cans Capacity

Bottle / Can Diameter

	2"	2.5"	3"	# Shelves
Bottle or Can Height 5.5"	32	18	12	2
6"	16	9	6	1
6.5"	16	9	6	1
7"	16	9	6	1
7.5"	16	9	6	1
8"	16	9	6	1
8.5"	16	9	6	1

WARRANTY: One Year Parts | 90 Days Labor **SPARE PARTS:** Inventoried

