

CT-2

MEDIUM COUNTER TOP COOLER

IN-HOUSE CUSTOM GRAPHICS CAPABILITIES



- 2 Cubic Foot Capacity
- Durable Steel Cabinet
- Forced Air Refrigeration with Ball Bearing Fan
- Self-Closing Door
- 2 Adjustable Shelves
- Low Energy Double Pane Tempered Glass Door
- Illuminated Sign Header
- Dual Recessed Interior Lighting
- Eco-Friendly R134a Refrigerant
- Custom Door Lock
- Exterior Thermostat Control
- Cools Down to 32°F/0°C

CT-2 MEDIUM COUNTER TOP COOLER

MEDIUM COUNTER TOP COOLER

- 2 Cubic Foot Capacity
- Durable Steel Cabinet
- Low Energy Double Pane Tempered Glass Door
- Exterior Light Switch
- Self-Closing Door
- Exterior On/Off Switch
- Recessed Handle
- Custom Door Lock
- Factory Engineered Refrigeration System
- Eco-Friendly R134a Refrigerant
- Exterior Thermostat Control
- Illuminated Sign Header
- 2 Adjustable Coated Heavy Wire Construction Shelves
- Adjustable Levelers
- ETL Certified
- Warranty
- Spare Parts Inventoried
- Dual Recessed Interior Side Lighting
- Cools Down to 32°F/0°C
- 115V/60HZ
- Custom Graphics Optional

SPECIFICATIONS

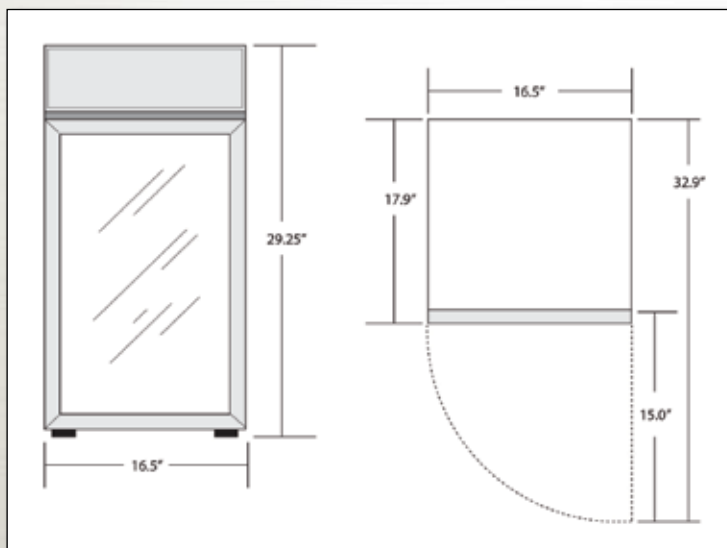

Exterior Dimensions: 16.5"W x 17.9"D x 29.25"H

Interior Dimensions: 13.2"W x 13"D x 17.4"H

Package Dimensions: 17.9"W x 19"D x 30.7"H

Units Per 40' Container: 360 **Net Wt:** 55.1 Pounds
Units Per Pallet: 12 **Gross Wt:** 59.5 Pounds
Pallets Per 53' Truck: 22
Units Per 53' Truck: 264

PRODUCT CAPACITY

Product Facings Per Shelf*:

- Six (6) of 2" Diameter Containers
- Five (5) of 2.5" Diameter Containers
- Four (4) of 3" Diameter Containers

*estimated

WARRANTY One Year Parts, 90 Days Labor

SPARE PARTS Inventoried

CT-2		# of Shelves	ESTIMATED TOTAL CAPACITY		
			Bottle / Can Diameter		
Bottle / Can Height	6"	2	72	50	32
	6.5"	2	72	50	32
	7"	2	72	50	32
	7.5"	2	72	50	32
	8"	2	72	50	32
	8.5"	1	36	25	16
	9"	1	36	25	16