

IC-19 19" ICE BARREL

IN-HOUSE CUSTOM GRAPHICS CAPABILITIES



ICE SEPARATOR

- Fill with Ice to Chill Product
- Perfect for Outdoor or Indoor Use
- Barrel Design Cooler
- Stimulates Impulse Purchases
- Low Profile Space Efficient
- Easy Lift Lid
- Easy Use Drain Nozzle
- Comes with 2" Casters
- Optional 360° Custom Graphic Wrap
- Ice Separator Included

IC-19 ICE BARREL

ICE BARREL COOLER

- 360° Graphic Wrap
- Barrel Design Cooler
- Ice Separator Included
- Stimulates Impulse Purchases
- Low Profile Space Efficient
- Easy Use Drain Nozzle
- Easy Lift Lid
- Comes with 2" Casters

SPECIFICATIONS

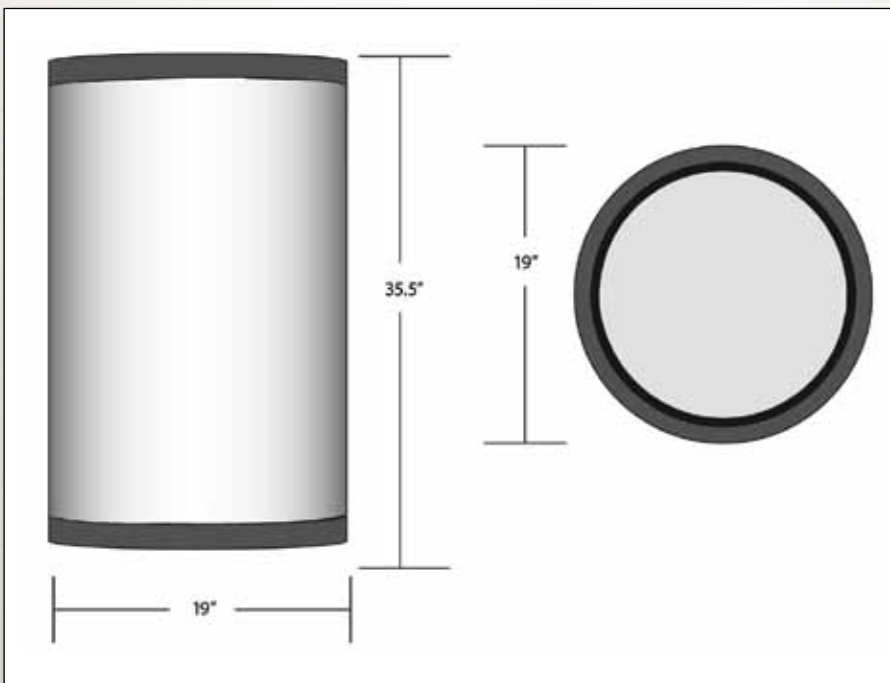

Exterior Dimensions: 19"Diam x 35.5"H

Interior Dimensions: 16"Diam x 18"H

Package Dimensions:

19.25"W x 19.25"D x 36"H

Net Wt: 18 Pounds

Gross Wt: 22 Pounds

Units Per Pallet: 15

Pallets Per 53' Truck: 22

Units Per 53' Truck: 264

PRODUCT CAPACITY

Estimated Product Capacity

- 75 8.4 Ounce Cans
- 60 12 Ounce Cans
- 40 16 Ounce Cans / 20 Ounce Bottles