

CT-3 FZ COUNTER TOP FREEZER

IN-HOUSE CUSTOM GRAPHICS CAPABILITIES



- 3 Cubic Foot Capacity
- Durable Steel Cabinet
- Low Energy Double Pane Heated Glass Door
- Forced Air Refrigeration with Ball Bearing Fan
- Automatic Defrost Cycle
- Illuminated Sign Header
- Self Closing Door
- Dual Recessed Interior Lighting
- 3 Adjustable Shelves
- Dual Side Interior Lighting
- Eco-Friendly R134a Refrigerant
- Custom Door Lock
- Exterior Thermostat Control
- Cools Down to -9°F/-23°C

CT-3 FZ LARGE COUNTER TOP FREEZER

LARGE COUNTER TOP FREEZER

- 3 Cubic Foot Capacity
- Durable Steel Cabinet
- Quality Baked-On Paint Finish
- Low Energy Double Pane Tempered Glass Door
- Exterior Light Switch
- Self Closing Door
- Recessed Handle
- Custom Door Lock
- Factory Engineered Refrigeration System
- Eco-Friendly R134a Refrigerant
- Exterior Thermostat Control
- Illuminated Sign Header
- Dual Side Interior Lighting
- 3 Adjustable Shelves
- Coated Heavy Wire Construction Shelves
- Adjustable Levelers
- Cools Down to -9°F/-23°C
- 115V/60HZ

SPECIFICATIONS

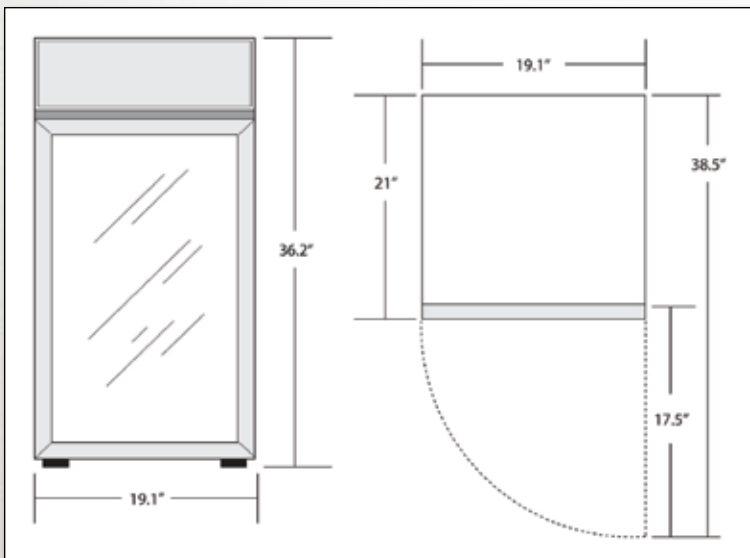

Exterior Dimensions: 19.1"W x 21"D x 36.2"H
Interior Dimensions: 13.6"W x 15.7"D x 21.4"H
Package Dimensions: 20.4"W x 22.5"D x 38"H

Units Per 40' Container: 184 **Net Wt:** 92.6 Pounds
Units Per Pallet: 8 **Gross Wt:** 97 Pounds
Pallets Per 53' Truck: 29
Units Per 53' Truck: 522

PRODUCT CAPACITY

Product Facings Per Shelf*:

- Six (6) of 2" Diameter Containers
- Five (5) of 2.5" Diameter Containers
- Four (4) of 3" Diameter Containers

*estimated

WARRANTY One Year Parts, 90 Days Labor
SPARE PARTS Inventoried

		CT-3 FZ	# of Shelves	ESTIMATED TOTAL CAPACITY		
				Bottle / Can Diameter		
Bottle / Can Height	6"	3	126	90	60	
	6.5"	3	126	90	60	
	7"	2	84	60	40	
	7.5"	2	84	60	40	
	8"	2	84	60	40	
	8.5"	2	84	60	40	
	9"	2	84	60	40	