

CT-2 FZ COUNTER TOP FREEZER

IN-HOUSE CUSTOM GRAPHICS CAPABILITIES



Ultra Energy Efficient Cooler*

NSF AND ETL CERTIFIED

Exterior Dimensions:
23"W x 23"D x 22.3"H

** ENERGY USAGE SIMILAR TO THAT
OF A 150 WATT LIGHT BULB*

- 2.4 Cubic Foot Capacity
- Ultra Energy Efficient Unit
- Interior LED Lighting
- Self-Closing Door
- Heated Glass Door
- Eco-Friendly Foams and Refrigerant
- 2 Adjustable Shelves
- Adjustable Thermostat
- Manual Defrost
- Cools Down to -20°F

CT-2 FZ FREEZER

COUNTER TOP FREEZER

- 2.4 Cubic Foot Capacity
- Ultra Energy Efficient Unit
- Interior LED Lighting
- Self Closing Door
- Heated Glass Door
- Eco-Friendly R134a Refrigerant
- 2 Adjustable Shelves
- Adjustable Thermostat
- NFS and ETL Certified
- Manual Defrost
- Cools Down to -20°F

SPECIFICATIONS

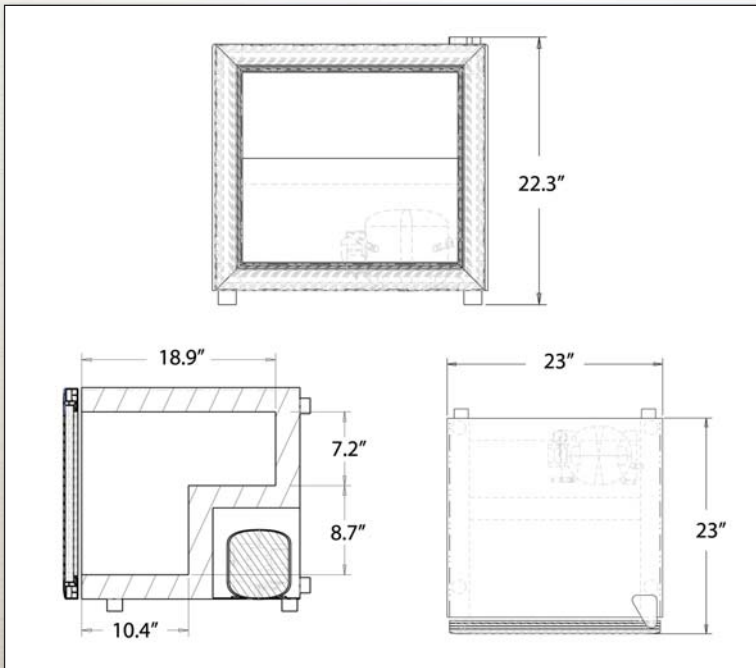

Exterior Dimensions: 23"W x 23"D x 22.3"H
Interior Dimensions: 18.3"W x 18.9"D x 15.9"H
Package Dimensions: 25"W x 25.4"D x 23.5"H

Net Wt: 88 Pounds

Gross Wt: 95 Pounds

Units Per 40' Container: 216

Units Per Pallet: 6

Pallets Per 53' Truck: 36

Units Per 53' Truck: 216

PRODUCT CAPACITY

Product Facings Per Shelf*:

Eight (8) of 2" Diameter Containers

Seven (7) of 2.5" Diameter Containers

Six (6) of 3" Diameter Containers **estimated*

WARRANTY One Year Parts / 90 Days Labor /
4 Years Compressor

SPARE PARTS Inventoried

ESTIMATED TOTAL CAPACITY

CT-2 FZ	# of Shelves	Bottle / Can Diameter			
		2"	2.5"	3"	
Bottle / Can Height	6"	2	128	98	72
	6.5"	2	128	98	72
	7"	2	128	98	72
	7.5"	1	64	49	36
	8"	1	64	49	36
	8.5"	1	64	49	36
	9"	1	64	49	36